



Digital Multimeter Model : 603



Instruction Manual

1

2

1. SPECIFICATIONS

1.1 General Specifications

Display	: 3 ½ digit liquid crystal display (LCD) with a maximum reading of 1999.
Polarity	: Automatic, (-)negative polarity indication
Zero adjustment	: Automatic
Overrange indication	: Highest digit of(1) or (-1) is displayed at MSD
Low battery	: "⎓" is displayed when the battery voltage drops below the operating voltage
Measurement rate	: 3 measurements per second, nominal.
Operating conditions	: 0°C to + 50°C at < 75% RH
Storage conditions	: -20°C to + 60°C, 0-80% RH with battery removed.
Accuracy	: Accuracy specifications at 23 ± 5°C, less than 75% RH.
Power Supply	: Single, standard 9-volt battery, Eveready 216 or equivalent.
Battery life (typical)	: 200 hours.
Dimensions	: 170 x 80 x 38 mm. (approx.)
Weight	: 250gms including battery (approx.)
Accessories	: Test leads (pair) x 1, spare fuse 0.8A/250V x 1, battery (installed) x 1, instruction manual x 1 & carrying case x 1

1.2 Electrical Specifications

Accuracies are ± (% reading plus number of digits) at 23 ± 5°C, and humidity of less than 75% RH.

DC VOLTAGE

Ranges	: 200mV, 2V, 20V, 200V, 1000V
Accuracy	: ±(0.5%rdg + 1dgt) on all ranges.
Resolution	: 100µV to 1V
Input Impedance	: 10MV
Overload Protection	: 500V DC/350VAC for 15 sec. on 200mV range, 1200V DC/800V AC on all other ranges.

AC VOLTAGE (50-500Hz)

Ranges	: 200mV, 2V, 20V, 200V, 750V
Accuracy	: ± (1% rdg + 4 dgt) on all ranges except ±(1.5% rdg + 4 dgt) on 750V
Resolution	: 100µV to 1V
Input Impedance	: 10MV
Overload Protection	: 500V DC/350VAC for 15 sec. on 200mV range, 1200V DC/800V AC on all other ranges.

DC CURRENT

Ranges	: 200mA, 2mA, 20mA, 200mA, 20A (In 20A range maximum measuring time ≤ 30s with an interval of 5 minutes.)
Accuracy	: ± (1% rdg + 1 dgt) on all ranges except ±(2% rdg + 3 dgt) on 20A range
Resolution	: 100nA to 10mA
Voltage Burden	: 325mV except, 1.4V max. on 20A range
Overload Protection	: 0.8A/250V FUSED. on all ranges except 24A unfused for 30 sec. on 20A range

AC CURRENT (50-500Hz)

Ranges	: 200mA, 2mA, 20mA, 200mA, 20A (In 20A range maximum measuring time ≤ 30s with an interval of 5 minutes.)
Accuracy	: ± (1.2% rdg + 4 dgt) on all ranges except ±(2% rdg + 4 dgt) on 20A range
Resolution	: 100nA to 10mA
Voltage Burden	: 325mV except, 1.4V max. on 20A range
Overload Protection	: 0.8A/250V FUSED on all ranges except 24A unfused for 30 sec. on 20A range

3

RESISTANCE

Ranges	: 200V, 2KV, 20KV, 200KV, 2000KV, 20MV, 200MV.
Accuracy	: ± (0.8% rdg + 1dgt) on all ranges except ± (1% rdg + 3 dgt) on 200V ± (3% rdg + 3 dgt) on 20MV ± (5% rdg + 10 dgt) on 200MV
Resolution	: 100mV to 100KV
Overload Protection	: 500V DC/AC
Test Voltage	: 200V, 200MV : 3.2V MAX. Other ranges 0.3V MAX.

CONTINUITY BEEPER

Threshold	: 100V approx.
Response Time	: 100mS

h_{FE} Test

Base DC Current	: 10 mA
V _{CE}	: 2.8 ± 0.4V
Range	: 0 To 1000

Diode Test

Test Current	: 1.0 ± 0.6mA
Test Voltage	: 3.2V max.

2. OPERATION

2.1 VOLTAGE MEASUREMENT

1. Connect red test lead to "V-V" input terminal and black test lead to "COM" input terminal.
2. Set Function/Range switch to desired voltage type (DC or AC) and range. If magnitude of voltage is not known, set switch to the highest range and reduce until a satisfactory reading is obtained.
3. Turn off power to the device or circuit being tested and discharge all capacitors.
4. Connect test leads to the device or circuit being measured.
5. Turn on power to the device or circuit being measured. Voltage value will appear on the digital display along with the voltage polarity.
6. Turn off power to the device or circuit being tested and discharge all capacitors prior to disconnecting test leads.

2.2 CURRENT MEASUREMENT

1. Connect red test lead to the "mA" input terminal for current measurements up to 200 milliamperes. Connect black lead to the COM input terminal.

4

2. Set Function/Range switch to desired current type (DC or AC) and range. If magnitude of current is not known, set switch to the highest range and reduce until a satisfactory reading is obtained.
3. Turn off power to the device or circuit being tested and discharge all capacitors.
4. Open the circuit in which current is to be measured. Now securely connect test leads in series with the load in which current is to be measured.
5. Turn on power to the device or circuit being tested.
6. Read current value on digital display.
7. Turn off all power to the device or circuit being tested and discharge all capacitors.
8. Disconnect test leads from circuit and reconnect circuit that was being tested.
9. For current measurement of 200mA or greater, connect the red test lead to "20 A" input terminal & black test lead to the "COM" input terminal. If the resistance being measured is part of a circuit, turn off power to the circuit and discharge all capacitors.

2.3 RESISTANCE MEASUREMENTS

1. Connect red test lead to V-V input terminal and black test lead to COM input terminal.
2. Set Function/Range switch to desired V position. If magnitude of resistance is not known, set the switch to highest range and reduce until a satisfactory reading is obtained.
3. If the resistance being measured is part of a circuit, turn off power to the circuit and discharge all capacitors.
4. Connect test leads to the device or circuit being measured. When measuring high resistance, be sure not to contact adjacent points even if insulated, because some insulators have a relatively low insulation resistance, causing the measured resistance to be lower than the actual resistance.
5. Read resistance value on digital display. If a high resistance value is shunted by a large value of capacitance, allow digits to stabilize.

NOTE

- A. All resistance ranges on the DMM, except the 200V and 200MV range, are low-power ohms. This allows accurate measurements of in-circuit resistance because the test voltage is below that is necessary to activate a diode junction
- B. The 200MV range has a fixed 10-count off set in its reading. When the test leads are shorted together in this range, the meter will display 010

in the 200MV range. This reading must be subtracted in order to obtain a true measurement. For example, when measuring a resistance of 100MV on the 200MV range, the display will read 110.

2.4 DIODE AND TRANSISTOR TEST MEASUREMENTS

The special Diode Test Function allows relative measurements of forward voltage drops across diodes and transistor junctions. This function also permits measurement of in-circuit semiconductor junctions.

2.4.1 DIODE TESTS

1. Connect red test lead to V-V input terminal and black test lead to COM input terminal.
2. Set Function/Range switch to the diode test position.
3. If the semiconductor junction being measured is part of a circuit, turn off power to the circuit and discharge all capacitors.
4. Connect test leads to the device.
5. Read forward voltage drop value on digital display.
6. If the digital display reads overrange (1) reverse the lead connections. The placement of the test leads when the forward reading is displayed indicates the orientation of the diode. The red lead is positive and the black lead is negative. If overrange (1) is displayed with both lead connections, the junction is open. If a low-reading (less than 1,000) is obtained with both lead connections, the junction is shorted internally or (if junction is measured in a circuit) the junction is shunted by a resistance less than 1KV. In the latter case the junction must be disconnected from the circuit in order to verify its operation.

2.4.2 TRANSISTOR JUNCTION TESTS

1. Bipolar transistors can be tested in the same manner as diode, junctions formed between the base and emitter and the base and collector of the transistor. Measurement between the collector and emitter also should be made to determine if a short is present.

2.5 TRANSISTOR hFE MEASUREMENTS

1. Transistor must be out of circuit. Set the function/range switch to the hFE position.
2. Plug the emitter, base and collector leads of the transistor into the correct holes in either the NPN or the PNP transistor test socket, whichever is appropriate for the transistor being checked. Read the hFE (beta, or DC current gain) in the display.

2.6 CONTINUITY MEASUREMENTS

1. Set the selectors switch to the $\square \{ \}$ position.
2. Continuity between probe tips will be indicated by an audible beep when resistance is below 100V.

6

3. MAINTENANCE

3.1 TROUBLESHOOTING

If there appears to be a malfunction during the operation of the meter, the following steps should be performed in order to isolate the cause of the problem:

1. Check the battery.
2. Review the operating instructions for possible mistakes in operating procedure.
3. Inspect and test the Test Probes for a broken or intermittent connection.
4. Inspect and test the fuse. If it is necessary to replace the fuse, be sure to install one of the proper current rating.

3.2 BATTERY AND FUSE REPLACEMENT

To prevent electrical shock hazard, turn off the multimeter and any device or circuit under test and disconnect the test leads before removing the battery snap or the rear cover.

a. BATTERY REPLACEMENT

1. Remove the battery cover screw, and slide the battery cover towards the bottom of the meter.
2. Remove and disconnect the old battery from the meter and replace with a new unit. Wind the excess lead length once around the battery clip. Install the battery and replace the battery cover.

CAUTION

Failure to turn off the multimeter before installing the battery could result in damage to the instrument and to the battery if the battery is connected incorrectly to the multimeter.

b. FUSE REPLACEMENT

1. Remove the battery cover screw, and slide the battery cover towards the bottom of the meter.
2. Remove the old fuse and replace with a new fuse rated for 0.8 amps. 250 volts. Use of wrong fuse could result in serious accident.

7



CERTIFICATE OF CALIBRATION

We hereby certify that this product has been calibrated and found to be in accordance with the applicable SPECIFICATIONS and MECO STANDARDS.

Accuracies of the standard equipment used in this calibration are traceable to the National Standards.

MECO METERS PVT. LTD.

Plot No. EL-60, MIDC Electronic Zone,
TTC Industrial Area, Mahape,
Navi Mumbai - 400710 (INDIA)

Tel : 0091-22-27673311-16, 27673300 (Board)

Fax : 0091-22-27673310, 27673330

E-mail : sales@mecoinst.com

Web : www.mecoinst.com

SR. NO. : _____

CHECKED BY : _____

DATE : _____

MODEL NO. : _____

8

603 : 28-09-2012



AUTORANGING DIGITAL MULTIMETER

MODEL : 9A06



INSTRUCTION MANUAL

FRONT PANEL CONTROLS

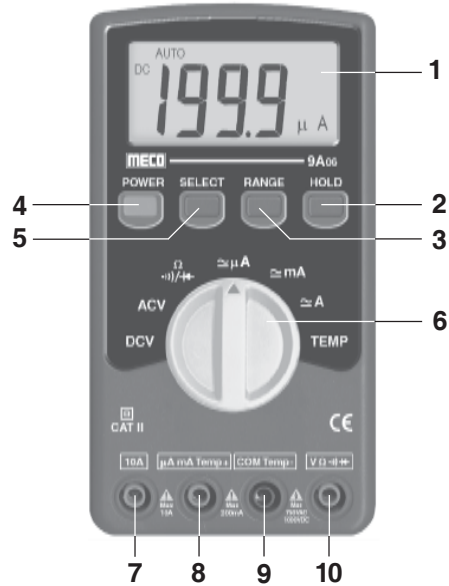

1. LCD Display
2. Hold Switch
3. Range Switch
4. Power ON / OFF Switch
5. Select Switch V / \rightarrow / \rightarrow / \rightarrow / \rightarrow / AC-DC / $^{\circ}$ C- $^{\circ}$ F
6. Function Switch
7. 10A Input Jack
8. μ A / mA / Temp (+) Input Jack
9. Common / Temp (-) Input Jack
10. V / V / \rightarrow / \rightarrow / \rightarrow / \rightarrow Input Jack

2

Getting Acquainted With Your Meter LCD Display Illustration

1		Low Battery Indication
2	AUTO	Auto Range Mode
3	AC	Alternating Current or Voltage
4	DC	Direct Current or Voltage
5	-	Digital Display for Reading
6		Diode Measurement Mode
7		Continuity Mode
8	M.H	Manual Hold
9	mV V	Voltage Measurement
10	mA mA A	Current Measurement
11	V kV MV	Resistance Measurement
12	$^{\circ}$C $^{\circ}$F	Centigrade / Fahrenheit Temperature Measurement

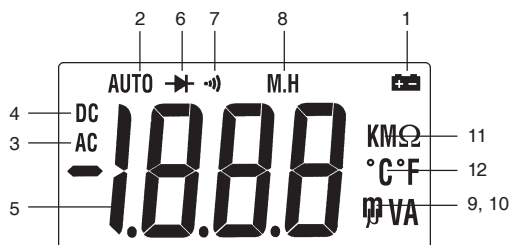

LCD DISPLAY 9A06

3

1. SPECIFICATIONS

1.1 General Specifications

- Display**
- 3 1/2 digit liquid crystal display (LCD) 22.0 mm height, max. reading 1999 with automatic decimal point selection annunciators of mv, V, μ A, mA, A, V, KV, MV, \rightarrow , \rightarrow , AC, DC, $^{\circ}$ C, $^{\circ}$ F, MH, AUTO,
- Range Selection**
- Auto & Manual for Voltage, Resistance, μ A, mA & A measurement.
- Polarity**
- Automatic, (-) negative polarity indication.
- Zero adjustment**
- Automatic
- Over range indication**
- 'OL' is displayd except in 1000VDC, 750VAC & 10A AC/DC range.
- Low battery**
- '

4

1.2 Electrical Specification

Accuracies are \pm (% reading plus number of digits) at $27 \pm 5^\circ\text{C}$ and humidity of less than 75% RH.

DC VOLTAGE (Auto & Manual Ranging)

Ranges : 200mV, 2V, 20V, 200V, 1000V
Accuracy : \pm (0.5% rdg + 4 dgt) on 200mV & 2V
 \pm (0.7% rdg + 4 dgt) on 20V & 200V
 \pm (1% of rdg + 4 dgt) on 1000V
Resolution : 100 μ V to 1V
Input Impedance : 10MV on all ranges except,
> 20MV on 200mV
11MV on 2V
Overload Protection: 500V DC/350V AC for 15 sec. on 200mV range, 1200V DC/800V AC on all other range.

AC VOLTAGE (Auto & Manual Ranging) 50-500Hz

Range : 200mV, 2V, 20V, 200V, 750V
(200mv range manual only)
Accuracy : \pm (1.0% rdg + 8 dgt) on all ranges except,
 \pm (1.5% rdg + 8 dgt) on 750V
Resolution : 1mV to 1V
Input Impedance : 10MV on all ranges except,
11MV on 2V
Overload Protection: 1200V DC/800V AC on all ranges.

DC CURRENT (Auto & Manual Ranging)

Range : 200 μ A, 2000 μ A, 20mA, 200mA, 10A
Accuracy : \pm (1.5% rdg + 4 dgt) on all ranges
Resolution : 100 μ A to 10mA
Burden Voltage : 325mV max on all ranges except,
750mV max on 10A range.
Overload Protection: 0.5A / 250V fused on all ranges except,
10A / 600V fused on 10A

5

AC CURRENT (Auto & Manual Ranging) 50-500Hz

Range : 200 μ A, 2000 μ A, 20mA, 200mA, 10A
Accuracy : \pm (2.2% rdg + 4 dgt) on all ranges
Resolution : 100 μ A to 10mA
Burden Voltage : 325mV max on all ranges except,
750mV max on 10A range.
Overload Protection : 0.5A / 250V fused on all ranges.
10A / 600V fuse on 10A

RESISTANCE (Auto & Manual Ranging)

Range : 200V, 2KV, 20KV, 200KV, 2MV, 20MV
Accuracy : \pm (0.7% rdg + 4 dgt) on all ranges except
 \pm (1.2% of rdg + 4 dgt) on 2MV
 \pm (2.5% of rdg + 4 dgt) on 20MV
Resolution : 0.1V to 10KV
Test Current : 0.7mA on 200V, 0.1mA on 2KV,
30 μ A on 20KV, 4 μ A on 200KV
Overload Protection : 500V DC/AC

Continuity Check

Threshold Level : 50V Approx.
Response Time : 1m Sec. Approx.
Open Circuit Voltage : 0.4V Approx.
Indication : '•)' is displayed on LCD and buzzer sounds at continuity.

Diode Test

Measurement Current : 1.0 \pm 0.6 mA Approx.
Open Circuit Voltage : 1.5V Approx.

Temperature

Range : -20°C to 1300°C
 -4°F to 1999°F
Accuracy : \pm (2.0% rdg + 4 dgt)
Resolution : 1°C
Sensor : K Type Thermocouple

6

2. OPERATION

MEASUREMENT PROCEDURE

SWITCH OPERATION

(A) POWER SWITCH

POWER switch enables to switch on the power to the meter.

(B) $\nabla / \rightarrow / \bullet$ / AC - DC / $^\circ\text{C}$ - $^\circ\text{F}$ SELECT SWITCH

The switch is used for Current, Resistance & Temperature measurement.

(a) In current measurement initially DC value is measured & 'DC' is displayed on LCD. To measure AC value press 'SELECT' switch. The display will change from 'DC' to 'AC'. Again switch over to 'DC' press the switch once more.

(b) In resistance measurement the switch is used to change over between $\nabla / \rightarrow / \bullet$ measurement.

(c) In temperature measurement the switch is used to change over $^\circ\text{C}$ - $^\circ\text{F}$ measurement. The corresponding annunciator will be displayed.

(C) RANGE SWITCH

RANGE switch is used to operate the meter in MANUAL mode.

The present range of the meter will be increased by pressing the RANGE switch. To come out of manual mode press RANGE switch for approx 2 seconds. The meter will operate in AUTO mode again and AUTO will be displayed on LCD.

(D) HOLD SWITCH

When HOLD switch is pressed the present data is locked and MH symbol appears on LCD. When HOLD switch is pressed again, the meter functions normally and MH sign disappears.

7

BUZZER

It sounds when operating SELECT switch, HOLD switch and RANGE switch.

It sounds for less than threshold level in continuity function.

AUTO POWER OFF

The meter will be switched off if no Function switch or key is used for approx 15 minutes. To restart press hold key.

2.1 VOLTAGE MEASUREMENTS (DC/AC)

1. Connect red test lead to 'V' input terminal and black test lead to 'COM' input terminal.
2. Set the function switch to (DCV or ACV) position.
3. Connect test lead to the device or circuit being measured.
4. Turn on power to the device or circuit being measured voltage value will appear on the digital display along with the voltage polarity.
5. Turn off power to the device or circuit being tested and discharge all capacitors prior to disconnecting test lead.

2.2 CURRENT MEASUREMENTS (DC/AC)

1. Switch on the multimeter by pressing 'POWER' switch.
2. Connect red test lead to the ' μA / mA' input terminal for current measurements up to 200 milliamperes. Connect black test lead to the 'COM' input terminal. For current greater than 200mA, connect red test lead to 'A' terminal.
3. Set Function switch to ' μA , mA & A' as per measurement. If the range of current to be measured is not known, start from the higher range ie. 'A' and change range as required.
4. Select DC or AC by Pressing 'SELECT' Switch.
5. Open the circuit in which current is to be measured. Now securely connect test leads in series with the load in which current is to be measured.

8

6. Turn on power to the device or circuit being tested.
7. Read current value on digital display.
8. Turn off all power to the device or circuit being tested and discharge all capacitors.
9. Disconnect test leads from circuit & reconnect circuit that was being tested.

2.3 RESISTANCE MEASUREMENTS

1. Switch on the multimeter by pressing 'POWER' switch.
2. Connect red test lead to 'V' input terminal and black test lead to 'COM' input terminal.
3. Set the Function Switch to 'V' position.
4. If the resistance being measured is part of a circuit, turn off power to the circuit and discharge all capacitors.
5. Connect test leads to the device or circuit being measured. When measuring high resistance, be sure not to contact adjacent points even if insulated, because some insulators have a relatively low insulation resistance, causing the measured resistance to be lower than the actual resistance.
6. Read resistance value on digital display. If a high resistance value is shunted by large value of capacitance, allow digits to stabilize.

NOTE : While measuring high resistance value more than one megohms, the digital reading is liable to receive the influence of noise, or of some insulators that have a relatively low insulation resistance. Therefore to make accurate measurements guard-shield is recommended. Black test leads is connected to the negative side.

2.4 DIODE & CONTINUITY

1. Switch on the meter by pressing 'POWER' switch.
2. Set FUNCTION switch to 'V' position.

9

2.4 A. Diode Check

1. Press 'SELECT' switch once, '→|' will be displayed.
2. Connect black test lead to the cathode side and red test lead to the anode side of the semiconductor. Display reading is forward voltage.
3. Connect the test leads in reverse of 2 above. If the display reading is same as when the leads are open, the semiconductor is good, otherwise it is defective.

Note : This test is influenced by the other devices connected to the diode. Hence isolate it before testing.

2.4 B. Continuity

1. Press 'SELECT' switch once '→|)' will be displayed.
2. Insert black test lead into 'COM' terminal and red test lead to 'V' Terminal.
3. Remove power from the circuit being tested and discharge all capacitors.
4. Connect the test leads to the circuit being measured. If resistance value is lower than 50V, buzzer sounds.

Note : Continuity test is to check continuity of the circuit. If precise data of resistance is needed, use 'V' function.

2.5 TEMPERATURE MEASUREMENT

1. Switch on the multimeter by pressing 'POWER' switch.
2. Set function switch to 'TEMP' position.
3. Connect 'Red' probe of K type thermocouple to 'mA / mA / TEMP (+)' terminal and 'Black' probe to 'COM / TEMP (-)' terminal.
4. Touch the end of temperature probe to the area or surface of the object whose temperature is to be measured. The display reading is in °C.
5. Press 'SELECT' switch to measure reading in °F scale.

10

IMPORTANT

To avoid heat damage to the meter, keep it away from sources of very high temperature. The life of the temperature probe is also reduced when subjected to very high temperatures.

(Operating Range is 0 to 1300°C)

3. MAINTENANCE

WARNING:

Remove test leads before changing batteries or fuse or performing any servicing. Never operate instrument unless bottom cover is closed.

3.1 TROUBLESHOOTING

If there appears to be a malfunction during the operation of the meter, the following steps should be performed in order to isolate the cause of the problem:

1. Check the battery.
2. Review the operating instructions for possible mistakes in operating procedure.
3. Inspect and test the Test Probes for a broken or intermittent connection.
4. Inspect and test the fuse. If it is necessary to replace the fuse, be sure to install one of the proper current rating.

3.2 BATTERY AND FUSE REPLACEMENT

To prevent electrical shock hazard, turn off the multimeter and any device or circuit under test and disconnect the test leads before removing the bottom cover.

11

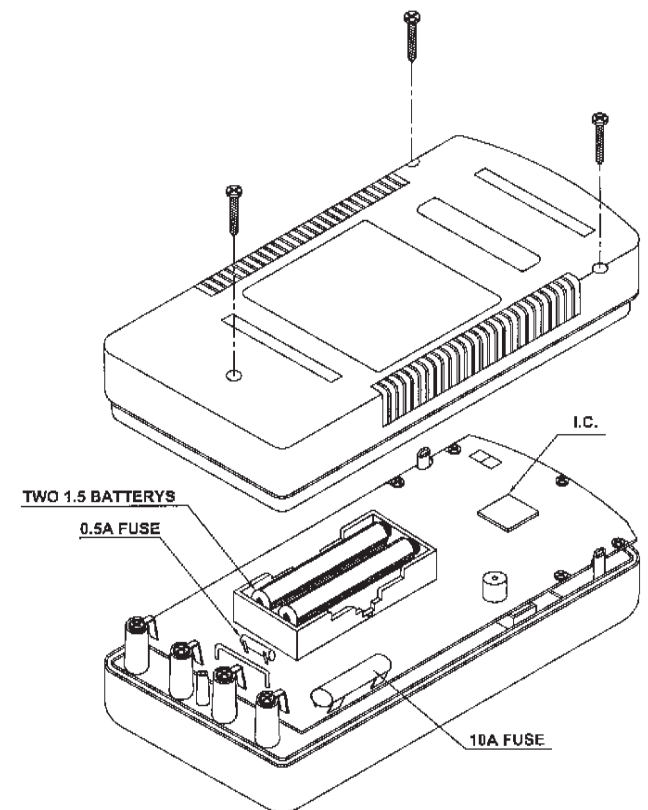



Diagram 'A'

12

A. BATTERY REPLACEMENT (Refer Diagram `A`)

'

B. FUSE REPLACEMENT (Refer Diagram `A`)

If no current measurements is possible, check for blown overload protection fuse. Open the bottom cover to the locate the fuse. Replace only with original type of fuse.

3.3 PRECAUTIONS

1. Observe all safety rules while making measurements. CAUTION should be exercised when making measurements since dangerous voltages can be present in normally safe circuit or areas.
2. Although this instrument is electronically and fuse protected against overloads, care should be taken to avoid excessive and repeated overloads when possible.
3. It is normal for this instrument digits to 'wander' when on the 'mV' range, since the DC input impedance is a very high. This high input impedance is needed when making accurate low voltage measurements.
4. If this instrument is NOT going to be operated for an extended period, remove the batteries since damage can result from leakage.

7. If possible, familiarize yourself with the equipment being tested and the location of its high voltage points. However, remember that high voltage may appear at unexpected points in defective equipment. Use an insulated floor material or floor mat to stand on and an insulated work bench surface; make certain such surfaces are not damp or wet.

4. SAFETY RULES

WARNING

An electrical shock causing 10 miliamps of current to pass through the heart will stop most human heartbeats. Voltage as low as 35 Volts DC or AC rms should be considered dangerous and hazardous since it can produce a fatal current under certain conditions. Higher voltage are even more dangerous. Observe the following safety precautions.

1. Do not exceed the following input ratings. Personal injury or damage to the instrument may result.

DC VOLTS	1000V (DC + AC peak)
AC VOLTS	750V rms
OHMS	250V rms
mA	200mA (fuse protected)
10A	10A (fuse protected)
COM	Do not float more than 1000 volts from earth ground.

2. Always check to make sure test lead plugs are fully inserted into input terminals and the function / range selector switch is set to the proper position.
3. Never use the multimeter unless the bottom cover is closed.
4. Remove test leads before replacing battery or fuses, and before performing any servicing on the multimeter.
5. Turn off equipment while making test connections in high voltage circuits. Discharge high-voltage capacitors after removing power.
6. For the safest voltage or current measurements in high voltage equipment, do not touch equipment, meter, or test leads while power is applied.



CERTIFICATE OF CALIBRATION

We hereby certify that this product has been calibrated and found to be in accordance with the applicable SPECIFICATIONS and MECO STANDARDS.

Accuracies of the standard equipment used in this calibration are traceable to the National Standards.

MECO METERS PVT. LTD.

Plot No. EL-60, MIDC Electronic Zone,
TTC Industrial Area, Mahape,
Navi Mumbai - 400710 (INDIA)

Tel : 0091-22-27673311-16, 27673300 (Board)

Fax : 0091-22-27673310, 27673330

E-mail : sales@mecoinst.com

Web : www.mecoinst.com

SR. NO : _____

CHECKED BY : _____

DATE : _____

MODEL NO : _____



AUTORANGING DIGITAL MULTIMETER MODEL : 801AUTO



INSTRUCTION MANUAL

FRONT PANEL CONTROLS

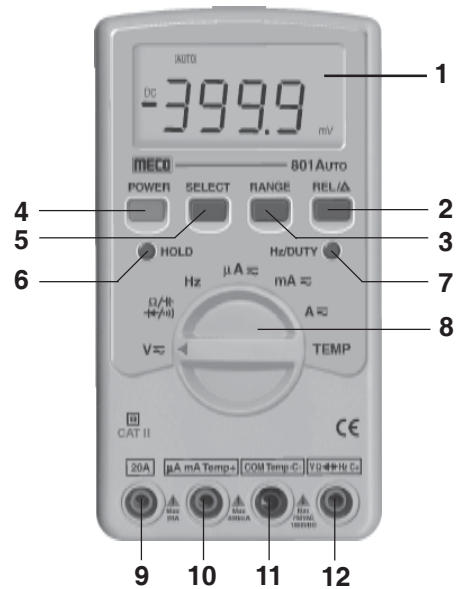

1. LCD Display
2. REL Δ Switch
3. Range Switch
4. Power ON / OFF Switch
5. V / \rightarrow / \leftarrow / AC-DC Select Switch
6. Hold Switch
7. Hz / Duty Switch
8. Function Switch
9. 20A Input Jack
10. μ A / mA / Temp+ Input Jack
11. Common / Temp- / C- Input Jack
12. V / V / \rightarrow / \leftarrow / C+ Input Jack

Getting Acquainted With Your Meter

LCD Display Illustration

1	-8888	Digital Display for Reading
2	DC	Direct Current or Voltage
3	AC	Alternating Current or Voltage
4	AUTO	Auto Range Mode
5	Δ	Manual Zero in Capacitance Measurement
6	H	Data Hold
7	Battery Icon	Low Battery Indication
8	Diode Symbol	Diode Measurement Mode
9	Continuity Symbol	Continuity Mode
10	kM Ω	Resistance Measurement
11	kMHz	Frequency Measurement
12	nmF	Capacitance Measurement
13	mV	Voltage Measurement
14	mA	Current Measurement
15	$^{\circ}$ C	Temperature Measurement
16	%	Duty Cycle Measurement

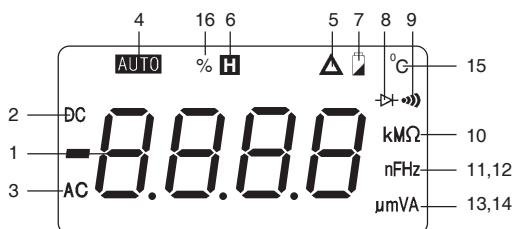

LCD DISPLAY 801Auto

1. SPECIFICATIONS

1.1 General Specifications

- Display**
- 3999 counts liquid crystal display (LCD) 15.0mm height, max. reading 3999, automatic decimal points selection and annunciators of mV, V, μ A, mA, A, V, KV, MV, AC, DC, \square , [AUTO], \rightarrow , nF, μ F, H, $^{\circ}$ C, %
- Range Selection**
- Auto & Manual for DC, AC Voltage, Resistance, μ A, mA & 'A' measurement Auto only for Frequency, capacitance, Temperature measurement
- Polarity**
- Automatic, (-) negative polarity indication
- Zero adjustment**
- Automatic for all ranges except capacitance (manual zero)
- Over range indication**
- 'OL' is displayed except in 1000V DC, 750V AC and 20A AC/DC range
- Low battery**
- 'B' mark turns on
- Sample rate**
- 3 measurement per second
- Operating conditions**
- 0 $^{\circ}$ C to +50 $^{\circ}$ C, 0 - 75% RH (Noncondensing)
- Storage conditions**
- -20 $^{\circ}$ C to +60 $^{\circ}$ C, 0 - 80% RH with battery removed
- Accuracy**
- Accuracy specification at 27 $^{\circ}$ \pm 5 $^{\circ}$ C and less than 75% RH
- Power Supply**
- Two Standard 1.5V battery Eveready type 1015 or equivalent
- Battery life (typical)**
- 200 hours
- Dimensions**
- 161 x 86 x 33 mm (approx.)
- Weight**
- 275gms including battery (approx.)
- Accessories**
- Test leads (pair) x 1, carrying case x 1, battery (installed) x 2, Instructional manual x 1 & K Type Thermocouple x 1

1.2 Electrical Specification

Accuracies are \pm (% reading + number of digits) at $27^\circ \pm 5^\circ\text{C}$ and humidity of less than 75% RH

DC VOLTAGE (Auto & Manual Ranging)

Range : 400mV, 4V, 40V, 400V, 1000V
Accuracy : \pm (0.5% rdg + 4 dgt) on 400mV & 4V
 \pm (0.7% rdg + 4 dgt) on 40V & 400V
 \pm (1.0% rdg + 4 dgt) on 1000V
Resolution : 0.1mV to 1V
Input Impedance : 10MV on all ranges
Overload Protection : 500V DC / 350V AC for 15 sec. on 400mV Range, 1200V DC / 800V AC on all ranges

AC VOLTAGE (Auto & Manual Ranging) 50-500Hz

Range : 4V, 40V, 400V, 750V
Accuracy : \pm (1.0% rdg + 5 dgt) on all ranges except,
 \pm (1.5% rdg + 8 dgt) on 750V
Resolution : 1mV to 1V
Input Impedance : 10MV on all ranges
Overload Protection : 1200V DC / 800V AC on all ranges

DC CURRENT (Auto & Manual Ranging)

Range : 400 μ A, 4000 μ A, 40mA, 400mA, 4A, 20A
Accuracy : \pm (1.5% rdg + 4 dgt)
Resolution : 0.1 μ A to 0.01A
Burden Voltage : < 0.7V on 200mA
< 0.25V on 20A
Overload Protection : 0.5A / 250V fuse on 400mA
20A / 600V fuse on 20A

AC CURRENT (Auto & Manual Ranging) 50-500Hz

Range : 400 μ A, 4000 μ A, 40mA, 400mA, 4A, 20A
Accuracy : \pm (2.2% rdg + 4 dgt)
Resolution : 0.1 μ A to 0.01A
Burden Voltage : < 0.7V on 400mA
< 0.25V on 20A
Overload Protection : 0.5A / 250V fuse on 400mA
20A / 600V fuse on 20A

RESISTANCE (Auto & Manual Ranging)

Range : 400V, 4KV, 40KV, 400KV, 4MV, 40MV,
Accuracy : \pm (0.7% rdg + 4 dgt) on all ranges except
 \pm (1.2% rdg + 4 dgt) on 4MV,
 \pm (2.5% rdg + 4 dgt) on 40MV
Resolution : 0.1V to 0.01MV
Test Current : Approx 0.7mA on 400V, 0.1mA on 4KV,
30 μ A on 40KV, 4 μ A on 400KV
Overload Protection : 500V DC/AC

FREQUENCY (Auto Ranging)

Range : 9.999Hz, 99.99Hz, 999.9Hz, 9.999kHz,
99.99kHz, 999.9kHz, 9.999MHz
Accuracy : \pm (0.5% rdg + 2 dgt)

% DUTY CYCLE (Auto Ranging)

Range : 0.1% to 99.9%
Accuracy : \pm (0.5% rdg + 2 dgt)
Resolution : 0.1%

CAPACITANCE (Auto Ranging)

Range : 40nF, 400nF, 4 μ F, 40 μ F, 100 μ F
Accuracy : \pm (5.0% rdg + 10 dgt)
Resolution : 1pF to 0.01nF

TEMPERATURE

Range : $-20^\circ\text{C} \sim 1300^\circ\text{C}$
Accuracy : \pm (2.0% rdg + 4 dgt)
Resolution : 1°C
Sensor : K Type Thermocouple

5

6

CONTINUITY CHECK

Threshold Level : 70V Approx.
Response Time : 1m Sec. Approx.
Open Circuit Voltage : 0.4V Approx.
Indication : '•)' is displayed on LCD and buzzer sounds at continuity

DIODE TEST

Measurement Current : 1.0 ± 0.6 mA Approx.
Open Circuit Voltage : 1.5V Approx.

2. OPERATION

MEASUREMENT PROCEDURE

SWITCH OPERATION

(A) POWER SWITCH

POWER switch enables to switch on the power to the meter.

(B) REL / Δ SWITCH

Press (REL / Δ) switch to enter the Relative mode. The Δ annunciator turns on. The display reading is stored as a reference value and the display becomes zero. The switch is functional in capacitance range only.

(C) RANGE SWITCH

RANGE switch is used to operate the meter in MANUAL mode. The present range of the meter will be increased by pressing the RANGE switch. To come out of manual mode, press the RANGE switch for approx 2 seconds. The meter will operate in AUTO mode again and AUTO will be displayed on LCD.

(D) SELECT SWITCH

The switch is used for voltage, current & resistance measurement.
a) In voltage and current measurement, initially DC value is measured and 'DC' is displayed on LCD. To measure AC value, the SELECT switch has to be pressed once. The display will change from 'DC' to 'AC'. To again switch over to DC, press the switch once more.

7

b) In resistance measurement this switch is used to change over between V, \rightarrow , \rightarrow , \rightarrow measurement. The corresponding annunciator will be displayed on LCD.

(E) HOLD SWITCH

When HOLD switch is pressed, the present data is locked and symbol **H** appears on LCD. When HOLD switch is pressed again the meter functions normally & sign disappears.

(F) HZ / DUTY SWITCH

Press this key to toggle between frequency & duty cycle measurement.

BUZZER

It sounds when operating SELECT Switch, REL / Δ Switch, Range Switch, Hold Switch & Hz / Duty Switch.

It sounds for less than threshold level in continuity function.

AUTO POWER OFF

By default, the meter is in auto power off mode. In this mode, the meter will be switched off after 15 minutes, if no range change is done. If this mode is not required, press the select key along with power on key. The auto power off mode will be turned off.

2.1 VOLTAGE MEASUREMENTS (DC/AC)

1. Switch on the multimeter by pressing 'POWER' switch.
2. Connect red test lead to 'V' input terminal & black test lead to 'COM' input terminal.
3. Set the Function Switch to 'V' position.
4. Select DC or AC by pressing 'SELECT' switch.
5. Connect test lead to the device or circuit being measured.
6. Turn on power to the device or circuit being measured. Voltage value will appear on the digital display along with the voltage polarity.
7. Turn off power to the device or circuit being tested and discharge all capacitors prior to disconnecting test lead.

8

2.2 CURRENT MEASUREMENTS (DC/AC)

1. Switch on the multimeter by pressing 'POWER' switch.
2. Connect red test lead to the 'μA / mA' input terminal for current measurements up to 400 milliamperes. Connect black test lead to the 'COM' input terminal.
3. For current measurement of 400mA or greater, connect the red test lead to '20A' input terminal & black test lead to the 'COM' input terminal. Set function switch to 'A' position.
4. Set Function Switch to 'μA' for μA measurement 'mA' for mA measurement and 'A' for A measurement. Do not keep the Meter in the circuit for more than 5 seconds when the function switch is on 'A' range.
5. Select DC or AC by Pressing 'SELECT' Switch.
6. Open the circuit in which current is to be measured. Now securely connect test leads in series with the load in which current is to be measured.
7. Turn on power to the device or circuit being tested.
8. Read current value on digital display.
9. Turn off all power to the device or circuit being tested and discharge all capacitors.
10. Disconnect test leads from circuit & reconnect circuit that was being tested.

2.3 RESISTANCE MEASUREMENTS

1. Switch on the multimeter by pressing 'POWER' switch.
2. Connect red test lead to 'V' input terminal and black test lead to 'COM' input terminal.
3. Set the Function Switch to 'V' position.
4. If the resistance being measured is part of a circuit, turn off power to the circuit and discharge all capacitors.
5. Connect test leads to the device or circuit being measured. When measuring high resistance, be sure not to contact adjacent points even if insulated, because some insulators have a relatively low insulation resistance, causing the measured resistance to be lower than the actual resistance.

9

6. Read resistance value on digital display. If a high resistance value is shunted by large value of capacitance, allow digits to stabilize.

NOTE : While measuring high resistance value more than one megohms, the digital reading is liable to receive the influence of noise, or of some insulators that have a relatively low insulation resistance. Therefore to make accurate measurements guard-shield is recommended. Black test leads is connected to the negative side.

2.4 DIODE, CONTINUITY & CAPACITANCE MEASUREMENT

1. Switch on the meter by pressing 'POWER' switch.
2. Set Function Switch to 'V' position.

2.4 A. Diode Check

1. Press SELECT switch once, '→' will be displayed.
2. Connect black test lead to the cathode side and red test lead to the anode side of the semiconductor. Display reading is forward voltage.
3. Connect the test leads in reverse of 2 above. If the display reading is same as when the leads are open, the semiconductor is good, otherwise it is defective.

Note : This test is influenced by the other devices connected to the diode. Hence isolate it before testing.

2.4 B. Continuity

1. Press SELECT switch once '••)' will be displayed.
2. Insert red test lead to 'V' terminal & black test lead to 'COM' terminal.
3. Remove power from the circuit being tested and discharge all capacitors.
4. Connect the test leads to the circuit being measured. If resistance value is lower than 70V, buzzer sounds.

Note : Continuity test is to check continuity of the circuit. If precise data of resistance is needed, use 'V' function.

2.4 C. Capacitance Measurement

1. Press SELECT switch once '←' will be displayed.
2. By Pressing REL / Δ Switch, get Zero display
3. Connect red test lead to C+ terminal & black test lead to C- terminal.

10

4. Discharge the capacitor before measuring
5. Connect the capacitor to the test lead for accurate measurements of low value capacitors. Connect the capacitor directly to the input terminals of the meter. Observe polarity while measuring polarised capacitors. Read capacitors value directly on the LCD.

2.5 FREQUENCY & DUTY CYCLE MEASUREMENTS

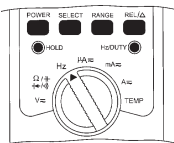

Fig. 1

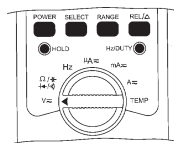

Fig. 2

There are 2 positions for Frequency & Duty cycle measurements.

- a) " Hz " position (Not for LINE Frequency measurement)
- b) " =V " position (For LINE Frequency measurement)

2.5a) " Hz " position (Not for LINE Frequency measurement) [Fig.1]

Sensitivity : 0.8V (10Hz to 500kHz)
3V ~ 30V (above 500kHz)

Frequency Range : 9.999 Hz to 9.999 MHz

Duty Cycle : .1% to 99.9%

Over Voltage Protect : 200V DC or AC Peak

- 1) Switch on the multimeter by pressing Power switch.
- 2) Connect test leads to VV & common terminal.
- 3) Set rotary switch to " Hz " position.
- 4) Select Frequency or Duty cycle by pressing " Hz / Duty " key.
- 5) Connect the test leads across the source or load under measurement.

2.5b) " =V " position (For LINE Frequency measurement) [Fig.2]

Sensitivity : 2V

Frequency Range : 40 Hz to 500 Hz.

Duty Cycle : .1% to 99.9%

Over Voltage Protect : 1000V DC or AC Peak

- 1) Switch on the multimeter by pressing Power switch.
- 2) Connect test leads to VV & common terminal.
- 3) Set rotary switch to " =V " position.
- 4) Select Frequency or Duty cycle by pressing " Hz / Duty " key.
- 5) Connect the test leads across the source or load under measurement.

2.6 TEMPERATURE MEASUREMENT

1. Switch on the multimeter by pressing 'POWER' switch.
2. Set function switch to 'TEMP' position.
3. Connect 'Red' probe of K type thermocouple to 'mA / mA / TEMP (+)' terminal and 'Black' probe to 'COM / TEMP (-)' terminal.
4. Touch the end of temperature probe to the area or surface of the object whose temperature is to be measured. The display reading is in °C.

11

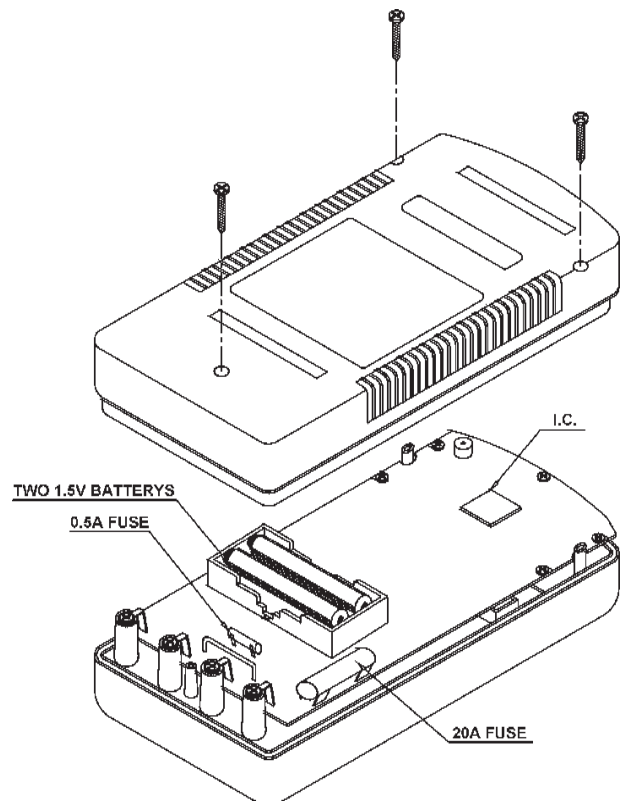

Diagram 'A'

12

IMPORTANT

To avoid heat damage to the meter, keep it away from sources of very high temperature. The life of the temperature probe is also reduced when subjected to very high temperatures.

(Operating Range is 0 to 1300°C)

3. MAINTENANCE

WARNING:

Remove test leads before changing batteries or fuse or performing any servicing. Never operate instrument unless bottom cover is closed.

3.1 TROUBLESHOOTING



If there appears to be a malfunction during the operation of the meter, the following steps should be performed in order to isolate the cause of the problem:

1. Check the battery.
2. Review the operating instructions for possible mistakes in operating procedure.
3. Inspect and test the Test Probes for a broken or intermittent connection.
4. Inspect and test both the fuses. If it is necessary to replace the fuse, be sure to install one of the proper current rating.

3.2 BATTERY AND FUSE REPLACEMENT (Refer Diagram 'A')

To prevent electrical shock hazard, turn off the multimeter and any device or circuit under test and disconnect the test leads before removing the bottom cover.

A. BATTERY REPLACEMENT

'  ' sign in display indicates LOW BATTERY. There are about 20 hours of operation left after '  ' first appears. Open the bottom cover and replace with two fresh 1.5V Eveready type 1015 or equivalent battery, observing polarity as marked. Incorrect polarity will cause display to remain blank. To prolong battery life, Switch OFF the POWER when not making measurement.

B. FUSE REPLACEMENT

If no current measurement is possible, check for blown overload protection fuses. Open the bottom cover to locate the fuse. Replace only with original type of fuse.

3.3 PRECAUTIONS

1. Observe all safety rules while making measurements. CAUTION should be exercised when making measurements since dangerous voltages can be present in normally safe circuit or areas.
2. Although this instrument is electronically and fuse protected against overloads, care should be taken to avoid excessive and repeated overloads when possible.
3. It is normal for this instrument digits to 'wander' when on the 'mV' range, since the DC input impedance is a very high. This high input impedance is needed when making accurate low voltage measurements.
4. If this instrument is NOT going to be operated for an extended period, remove the battery since damage can result from leakage.

4. SAFETY RULES

WARNING

An electrical shock causing 10 milliamps of current to pass through the heart will stop most human heartbeats. Voltage as low as 35 Volts DC or AC rms should be considered dangerous and hazardous since it can produce a fatal current under certain conditions. Higher voltage are even more dangerous. Observe the following safety precautions.

1. Do not exceed the following input ratings. Personal injury or damage to the instrument may result.

DC VOLTS 1000V (DC + AC peak)

AC VOLTS 750V rms

OHMS	250V rms
mA	400mA (fuse protected)
20A	20A (fuse protected)
COM	Do not float more than 1000 volts from earth ground.

2. Always check to make sure test lead plugs are fully inserted into input terminals and the function / range selector switch is set to the proper position.
3. Never use the multimeter unless the bottom cover is closed.
4. Remove test leads before replacing battery or fuses, and before performing any servicing on the multimeter.
5. Turn off equipment while making test connections in high voltage circuits. Discharge high-voltage capacitors after removing power.
6. For the safest voltage or current measurements in high voltage equipment, do not touch equipment, meter, or test leads while power is applied.
7. If possible, familiarize yourself with the equipment being tested and the location of its high voltage points. However, remember that high voltage may appear at unexpected points in defective equipment. Use an insulated floor material or floor mat to stand on and an insulated work bench surface; make certain such surfaces are not damp or wet.



Certificate of Calibration

We hereby certify that this product has been calibrated and found to be in accordance with the applicable SPECIFICATIONS and STANDARDS.

Accuracies of the standard equipment used in this calibration are traceable to the National Standards.

MECO METERS PVT. LTD.

Plot No. EL-60, MIDC Electronic Zone, TTC Industrial Area, Mahape, Navi Mumbai - 400710 (INDIA)

Tel : 0091-22-27673311-16, 27673300 (Board)

Fax : 0091-22-27673310, 27673330

E-mail : sales@mecoinst.com

Web : www.mecoinst.com

SR. NO. : _____

CHECKED BY : _____

DATE : _____

MODEL NO. : _____